

UFO²

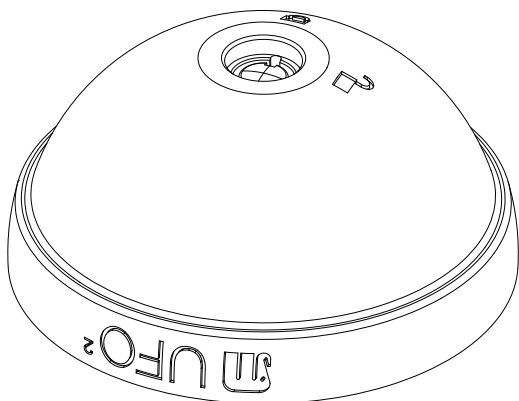

ALTEZZA DI INSTALLAZIONE SUGGERITA
SUGGESTED INSTALLATION HEIGHT
ALTURA DE INSTALACIÓN SUGERIDA
HAUTEUR D'INSTALLATION SUGGÉRÉE

INDEX

FORD

Transit Connect	6
Transit Courier	7
Transit Custom	8
Transit Van	9

VOLKSWAGEN

Caddy	10
Transporter	11
Crafter	12

FIAT

Doblò	13
Ducato	14
Fiorino	15
Talento	16

IVECO

Daily	17
-------	----

MERCEDES

Citan	18
Sprinter	19
Vito	20

RENAULT

Kangoo	21
Master	22
Trafic	23

CITROËN

Berlingo Van	24
Jumpy / Dispatch	25
Nemo	26
Jumper / Relay	27

OPEL | VAUXHALL MOTORS

Combo	28
Movano Van	29
Vivaro	30

PEUGEOT

Bipper	31
Boxer	32
Expert	33
Partner	34

DACIA

Dokker	35
--------	----

NISSAN

NV300	36
NV400	37

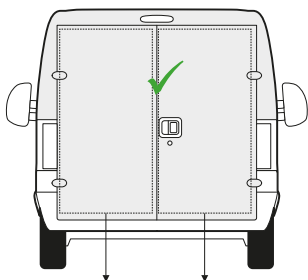

IT Porta fissa
EN Fixed door
ES Puerta fija
FR Porte fixe

Porta battente
Swing door
Puerta batiente
Porte battante

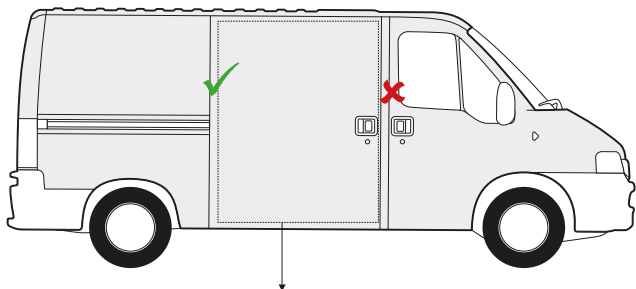

IT Porta scorrevole
EN Side loading door
ES Puerta corredera
FR Porte coulissante



TRANSIT CONNECT
2014 » present

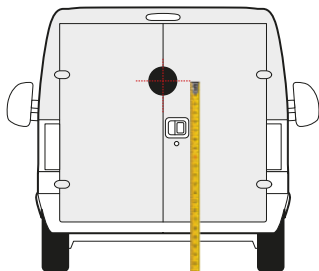

1500mm

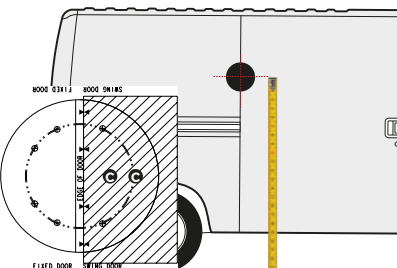

1500mm

IT Per i fori **C** seguire le istruzioni a pagina 38

EN For holes **C** follow the instructions on page 38

ES Para los agujeros **C**, siga las instrucciones de la página 38

FR Pour les trous **C**, suivez les instructions de la page 38



TRANSIT COURIER
2013 » present

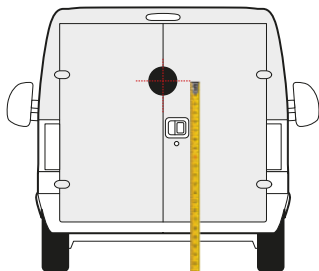

1450mm

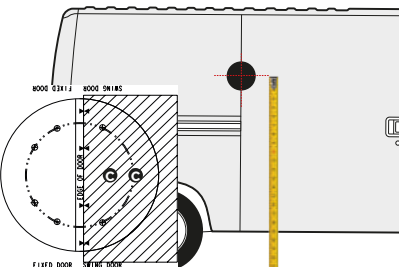

1450mm

IT Per i fori **C** seguire le istruzioni a pagina 38

EN For holes **C** follow the instructions on page 38

ES Para los agujeros **C**, siga las instrucciones de la página 38

FR Pour les trous **C**, suivez les instructions de la page 38



TRANSIT CUSTOM
2018 » present

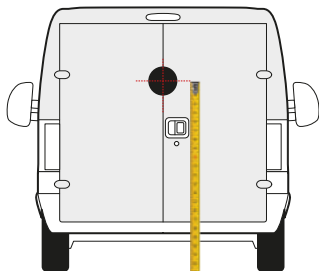

1600mm

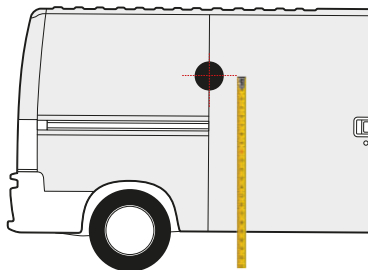

1600mm



TRANSIT VAN
2019 » present

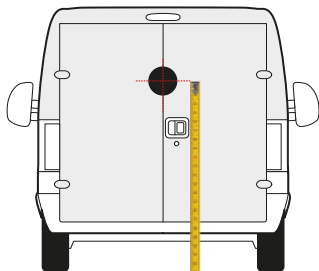

1700mm

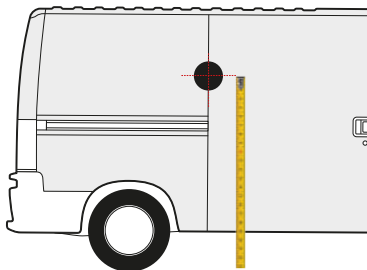

1650mm



CADDY
2015 » present

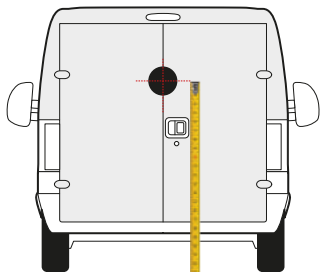

1500mm

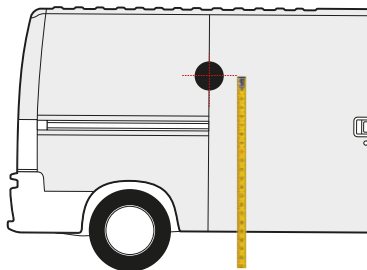

1450mm



TRANSPORTER 2015 » present

1500mm

IT Per i fori **C** seguire le istruzioni a pagina 38

EN For holes **C** follow the instructions on page 38

ES Para los agujeros **C**, siga las instrucciones de la página 38

FR Pour les trous **C**, suivez les instructions de la page 38

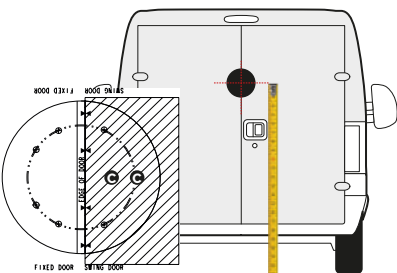

1400mm

IT Per i fori **C** seguire le istruzioni a pagina 38

EN For holes **C** follow the instructions on page 38

ES Para los agujeros **C**, siga las instrucciones de la página 38

FR Pour les trous **C**, suivez les instructions de la page 38

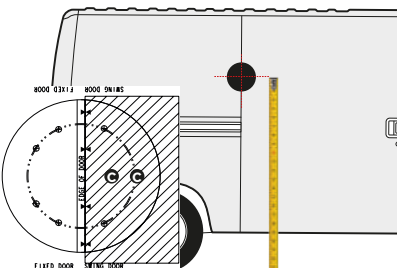



CRAFTER
2017 » present

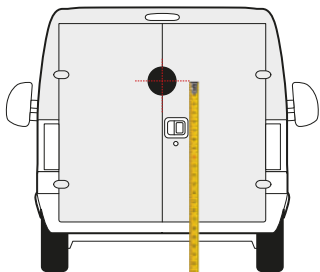

1800mm

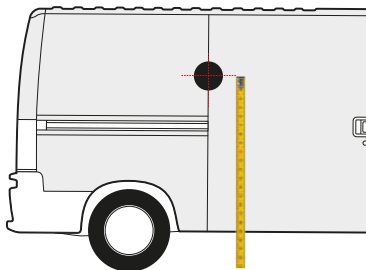

1800mm



DOBLÒ
2009 onwards

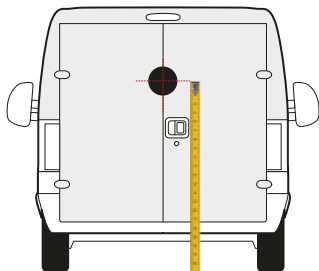

1600mm

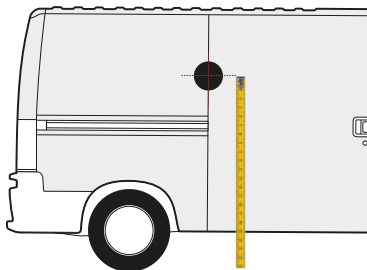

1500mm



DUCATO
2006 » present

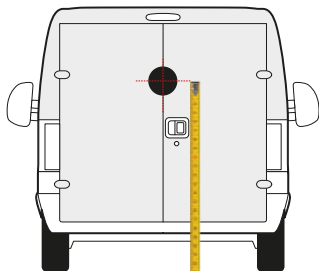

1650mm

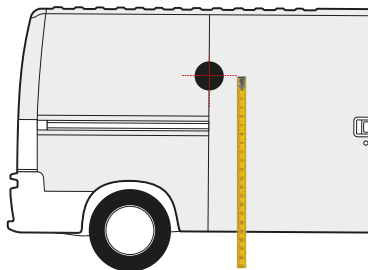

1650mm



FIORINO
2007 onwards

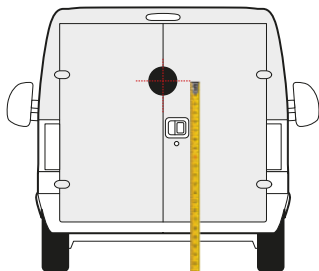

1300mm

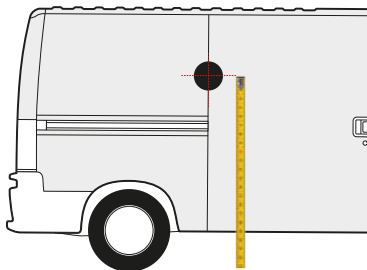

1200mm



TALENTO
2016 » present

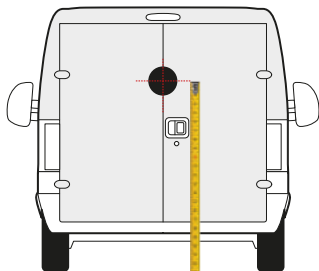

1550mm

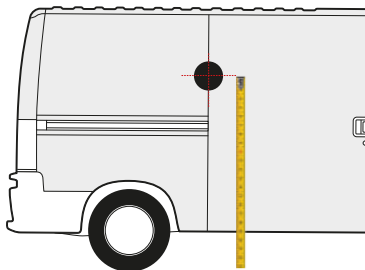

1400mm

IVECO



DAILY
2014 » present

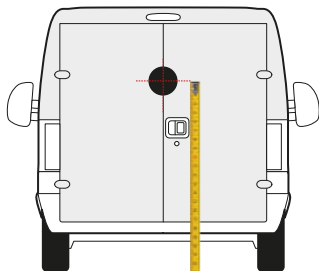

1800mm

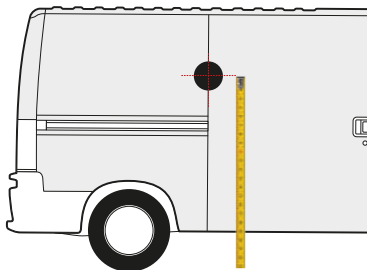

1700mm



CITAN
2012 » present

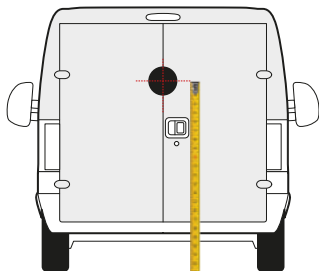

1400mm

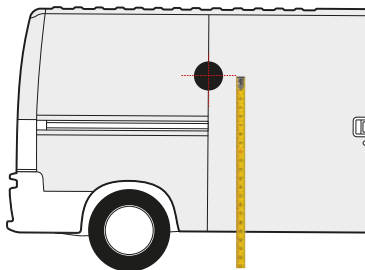

1350mm



SPRINTER
2018 » present

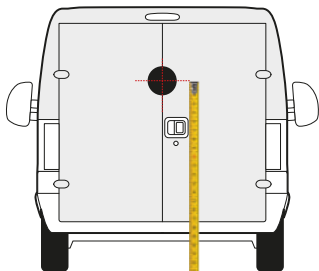

1700mm

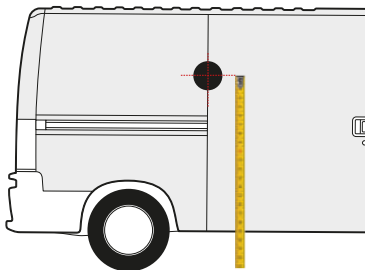

1600mm



VITO
2015 » present

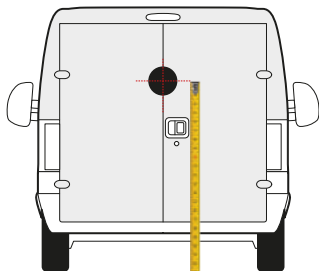

1450mm

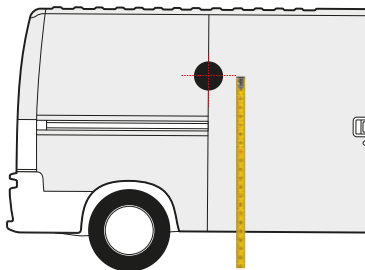

1450mm



KANGOO
2009 » *present*

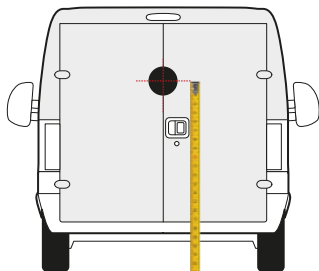

1350mm

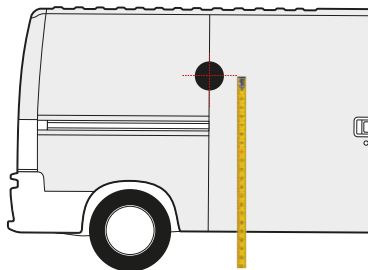

1350mm



MASTER
2010 » present

1600mm

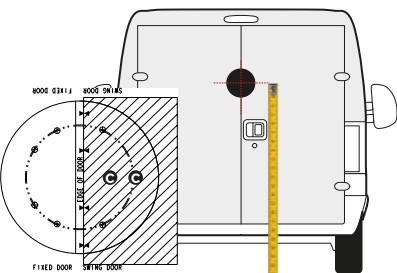

IT Per i fori **C** seguire le istruzioni a pagina 38

EN For holes **C** follow the instructions on page 38

ES Para los agujeros **C**, siga las instrucciones de la página 38

FR Pour les trous **C**, suivez les instructions de la page 38

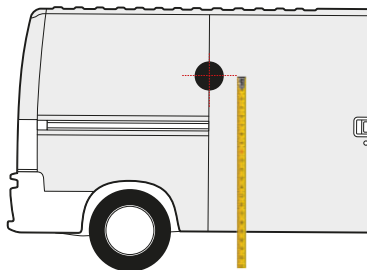

1600mm



TRAFIC
2014 » present

1550mm

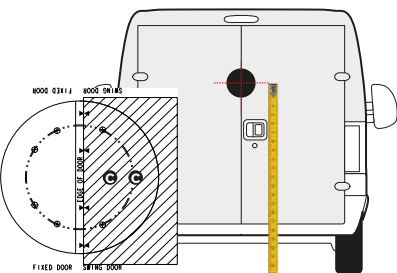

IT Per i fori **C** seguire le istruzioni a pagina 38

EN For holes **C** follow the instructions on page 38

ES Para los agujeros **C**, siga las instrucciones de la página 38

FR Pour les trous **C**, suivez les instructions de la page 38

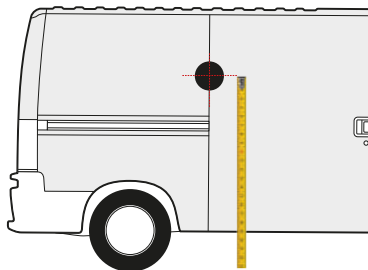

1400mm



BERLINGO VAN
2018 » present

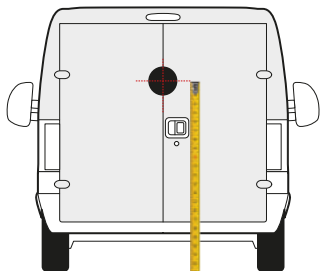

1450mm

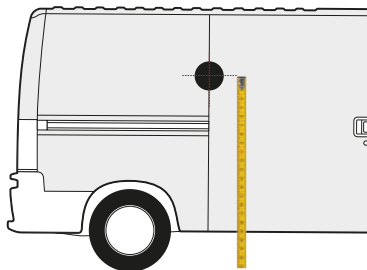

1400mm



JUMPY / DISPATCH
2016 » present

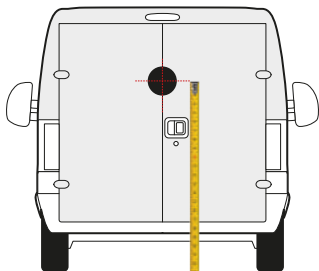

1500mm

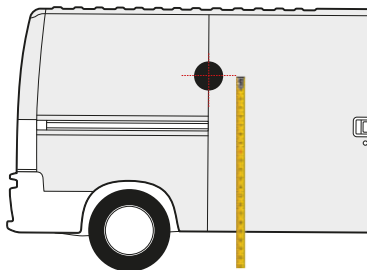

1500mm



NEMO
2008 » 2013

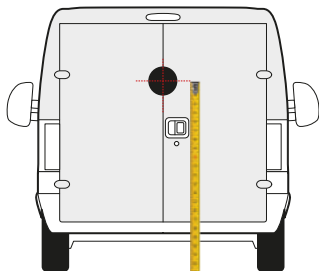

1300mm

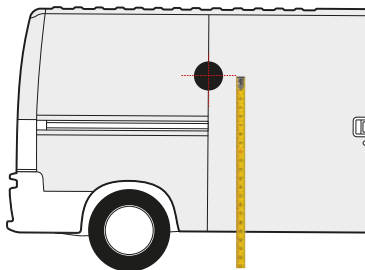

1200mm



JUMPER / RELAY
2014 onwards

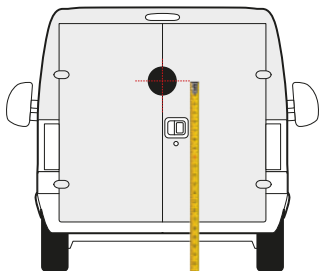

1650mm

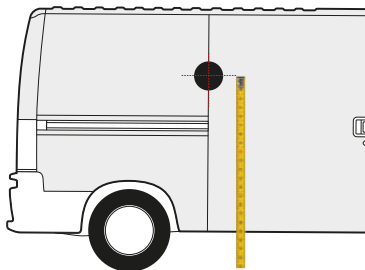

1650mm



COMBO
2019 » present

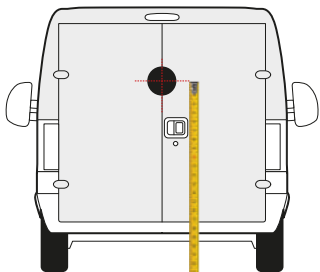

1600mm

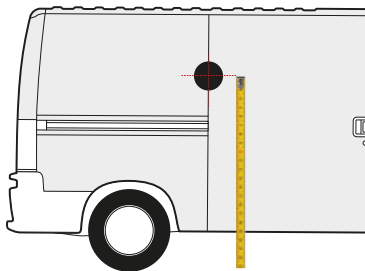

1500mm



MOVANO VAN
2010 » *present*

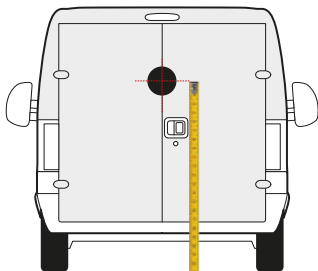

1600mm

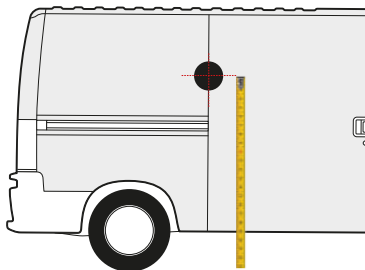

1600mm



VIVARO
2019 » present

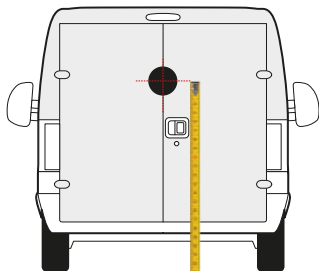

1550mm

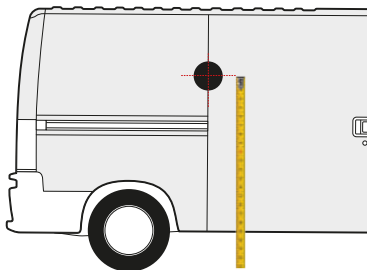

1400mm



BIPPER
2008 » 2016

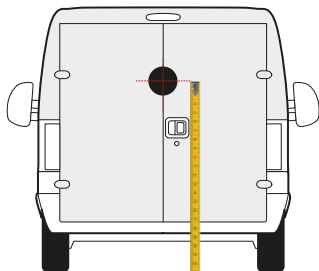

1300mm

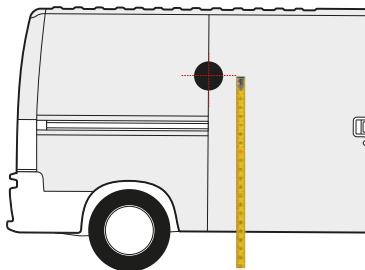

1200mm



BOXER
2006 » present

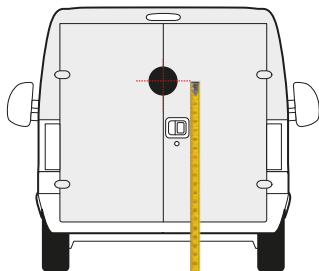

1650mm

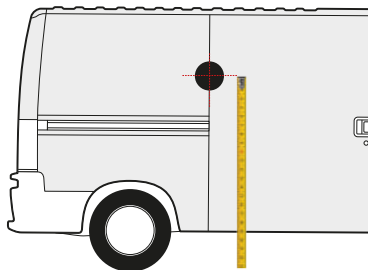

1650mm



EXPERT
2016 » present

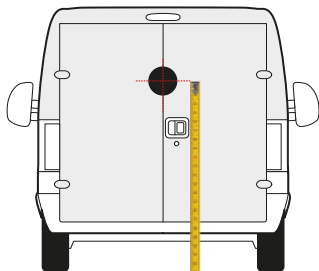

1550mm

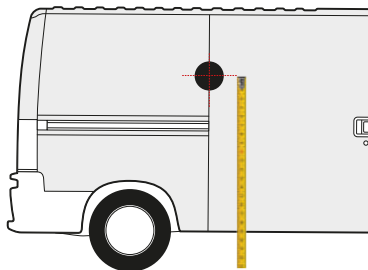

1350mm



PARTNER
2018 » *present*

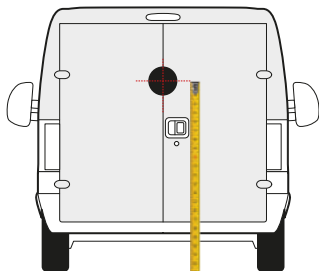

1450mm

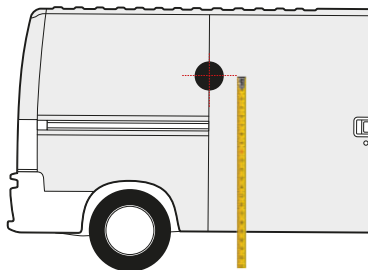

1400mm



DOKKER
2013 » present

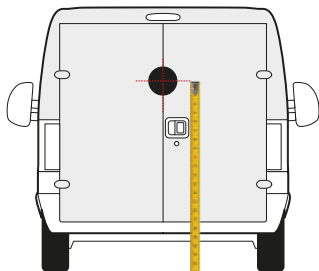

1400mm

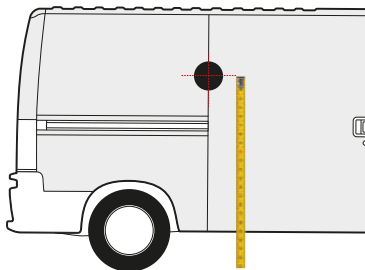

1400mm



NV300
2014 » present

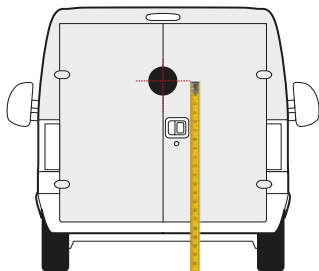

1550mm

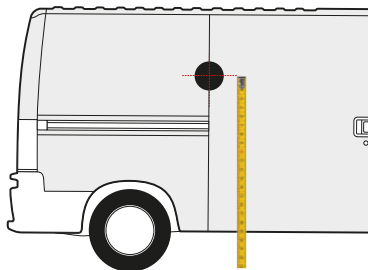

1400mm



NV400
2011 » present

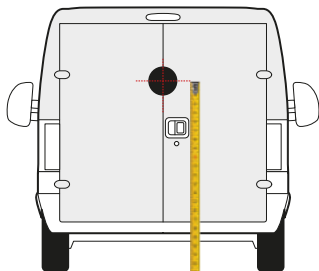

1600mm

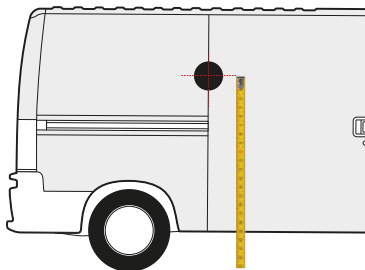

1600mm

1

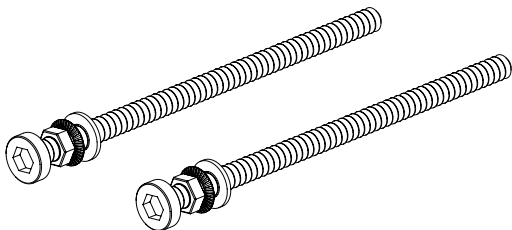
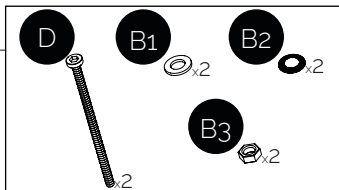

IT Inserire dado, rondella zigrinata e rondella piana nelle 2 viti lunghe **D**

EN Insert nut, serrated washer and plane washer onto the 2 long screws **D**

ES Introduzca la tuerca, la arandela dentada y la arandela en los 2 tornillos largos **D**

FR Insérez l'écrou, la rondelle dentelée et la rondelle dans les 2 vis longues **D**

2

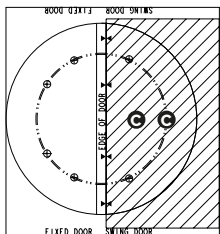
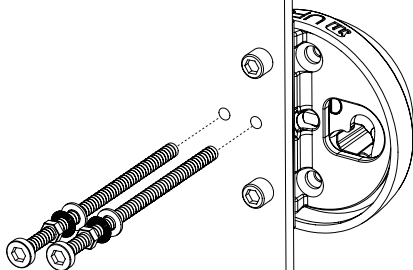

IT Avvitare la calotta L con 2 viti D (coppia 2Nm) nei fori C

EN Now secure the shell L with 2 screws D (torque 2Nm) in positions C

ES Atornillar la cáscara L con 2 tornillos D (par 2Nm) en las posiciones C

FR Visser la coquille L avec 2 vis D (couple 2Nm) en position C

3

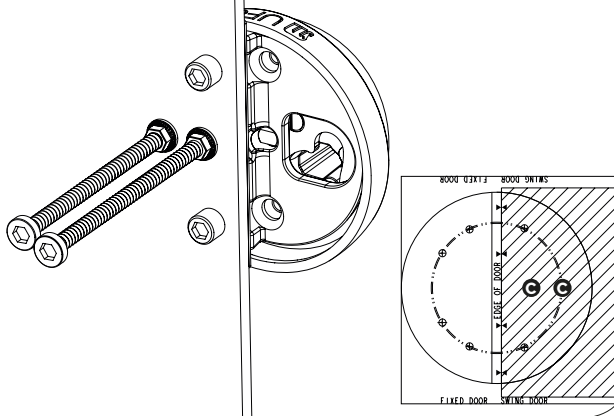

IT Dopo aver fissato i dadi, tagliare la parte di vite in eccesso

EN Tighten the nuts against the bodywork (torque 2Nm) and then cut off the excess of the screws

ES Después de apretar las tuercas, corte el tornillo sobrante

FR Après avoir serré les écrous, coupez l'excédent de vis

4

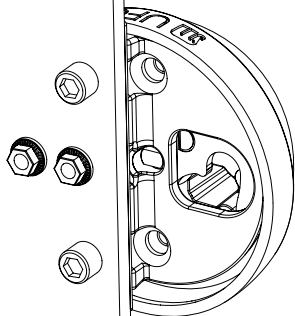

IT L'installazione è completa

EN The installation is now complete

ES La instalación está completa

FR L'installation est terminée

AVVERTENZA
WARNING
ADVERTENCIA
AVERTISSEMENT

IT Tutti i dati contenuti nelle istruzioni di montaggio sono indicativi, e non vincolanti, in quanto l'Azienda produttrice, si riserva il diritto di apportarvi qualsiasi modifica o variazione senza alcun preavviso.

EN All the information contained in the fitting instructions are indicative and not binding, as the manufacturer reserves the right to make any changes or variations without prior notice.

ES Todos los datos contenidos en las instrucciones de montaje son indicativos y no vinculantes, ya que la empresa fabricante se reserva el derecho de realizar cualquier cambio o variación sin previo aviso.

FR Toutes les données contenues dans les instructions de montage sont indicatives et non contraignantes, car la société de fabrication se réserve le droit d'apporter des modifications ou des variations sans préavis.

VIDEO DI INSTALLAZIONE
INSTALLATION VIDEO
VIDEO DE INSTALACIÓN
VIDÉO DE L'INSTALLATION



<https://www.youtube.com/user/serraturemeroni>

MERONI SERRATURE

Cerraval

P.I. Fuente del Jarro Carrer
Islas Canarias 29 46988
Paterna, Valencia
t: +34 96 1325395
e: cerraval@cerraval.es
w: cerraval.es

Serrature Meroni S.p.A.

via Valsorda snc, S.P. 40
Inverigo (CO) - Italia
t: +39 031 6949301
e: ufo@serme.it
w: ufomeroni.com